

ELECTRIC SOUND

for various uses by



DCv3 rev11

CAUTION: This device can be damaged by static discharge. Please exercise care during installation to avoid this possibility. Discharge yourself to an electrical ground (outlet cover screw) before removing this device from its anti-static bag. Please read instruction sheet completely before attempting to install and operate this product. Save the anti-static bag for possible reuse of storing or shipping the sound unit!

OVERVIEW: This device is an electronic, self contained, sound system for installation in model electric locomotives that are designed to operate with conventional DC track power, digital (DCC) or other types of command control systems including radio with either track or battery power, also as a stationary sound unit. Because of its dimensions (2.7" x 0.9" x approx. 0.5" high) the sound system may be limited to installations in some powered units making the need for use of a "dummy" unit or a trailing car. An alternative installation under the layout is also possible including the use of our TRAK-DT devices to switch the sound through multiple speakers so as to follow the movement of the train. A drawing for this application is in our Model Railroaders Wiring Guide.

An on/off switch (not included) must be used to power the sound unit on and off in some applications. The audio amplifier can produce one watt of power which is in excess of what most small speakers can handle. The speaker impedance must be 8 ohms or higher. Sound volume is adjustable. Refer to our catalog for available speakers. If space permits, the optional oval speakers (Items 662, 664, 665), which are higher wattage speakers, are the best choice.

Sounds produced include user controlled horn, bell force cooling fans and main sounds on/off (leaves the main sounds off while allowing for horn and bell operation). Non-user controllable sounds brake release and electric cooling fans sound. These automatically operate. The cooling fans can be manually controlled.

This sound system, when used with conventional DC track power, requires the use of our LocoMatic™ Controller (Item 755) to operate the horn, bell, force cooling fans, and main sounds on/off. DCC and other command control operators can use remote functions on their systems to activate the same functions. For stationary installations, these functions can be accessed by switches. Radio control with fixed track power or on board batteries would be similar to DCC installations and large gauge (where you ride the locomotive) would be similar to a stationary installation.

INSTALLATION INSTRUCTIONS: The sound system consists of a printed circuit board, a speaker, five 2-pin connectors with wires and one 3-pin connectors with wires. A CHOKE (item 70 or 703 depending on motor power requirements), not included, is required for DC track power installations.

Refer to the drawing on page 2 to familiarize yourself with the connectors and controls on the sound board. Then refer to the specific instruction sheets for the type of installation you intend to make. Before proceeding with the installation read the balance of the instructions carefully so you will be completely familiar with what is required and what sounds you should hear.

The circuit board should be mounted so that at minimum, the volume control is accessible either through the frame or via a hatch or a hole in the locomotive body shell. Be certain that the components on the circuit board do not come in contact with any metal objects as such contact can destroy the sound system. The speaker should be mounted as per available space bearing in mind that sound reproduction is enhanced when a speaker is properly enclosed and baffled.

If a DC locomotive is not moving, there is no track power, therefore to have sound it is necessary to have a separate power supply for the sound system. For in locomotive use, this separate supply is a battery. We suggest the use of one 9 volt or 6 AA or 6 AAA batteries in series to maximize volume potential and battery life. Rechargeable batteries can be used. When connecting the battery (DC) power leads be absolutely certain that wires connect to the proper DC input leads.

If any connections are not done properly, especially the power connections, you will damage the sound system. This type of damage is not covered under any warranty. The sound system is thoroughly tested and inspected before packing to insure proper function. There is a minimum charge of \$40.00 plus s/h for repair.

SOUND INFORMATION:

Cooling Fans (Electric): sounds range from idle (silent - no fans operate when not running) to full fan rpm. With no power to the track / motor the sound system will produce no sounds. As a throttle is advanced to put the locomotive in motion, a brake release will sound (see below) and the electric fans will accelerate to full rpm. With our LocoMatic™ Controller (#755), activating the ALT and F3 buttons simultaneously (and then releasing) will direct the sound system to ramp the fans to full RPM regardless of track / motor voltage. Activating both buttons again will release the sound system to return to the correct fan setting. This feature allows the simulation of more cooling when sitting after a heavy load run or "pumping air" in a standing train. This full fan RPM feature is available to other users either by a switch or with a remote function. The cooling fans, air pops, and brake release sounds can be turned off without turning off the sound system. This way you can still activate the Horn and Bell. With our LocoMatic™ Controller, use ALT F4 as a push on, push off. For other receivers or stationary, a function or single pole switch will suffice.

BRAKE RELEASE: sound is produced when the throttle is advanced from the idle position. This brake release should always precede locomotive movement. For DC operators, this requires approximately 1.5 to 2 volts of input voltage to sense a running mode for the brake release to sound.

HORN: sound is controlled by the HORN button on the LocoMatic™ Controller, by a momentary push button or by remote function, dependent upon the type of installation. The HORN will sound as long you are holding the control on. This will allow you to actually play the sound as on a real locomotive. DCC and similar systems will have a sound delay equivalent to system response time.

BELL: sound is controlled by the BELL button on the LocoMatic™ Controller, by a toggle switch or by remote function, dependent upon the type of installation. The sound system includes a routine which ignores intermittent BELL requests, resulting in a delay when activating or deactivating the BELL. With the LocoMatic™ Controller you depress and release the BELL button to turn on the BELL and then again depress and release the button to turn the BELL off. Toggle switch or remote function control does not require the PUSH ON - PUSH OFF sequence.

SPEAKER MOUNTING: The speaker generally should be mounted so that the sound can actually "get out" of the locomotive. A hole in the floor or fuel tank is acceptable but open grills or a doorway may be a better choice as the sound can exit upward rather than down toward the track. In some cases, particularly with plastic body shells, just mounting the speaker against the shell will be adequate as the vibrations of the shell can enhance the sound. Enclosing the speaker in a chamber will also enhance sound reproduction. A very simple enclosure can be made with a tube. The longer the tube the better the speaker will reproduce low frequency sound which is inherent in electric cooling fans. It is usually best to seal the end of the tube, so there are no air passages to the rear of the speaker, thus creating a sound chamber. By carefully sealing all openings it may be possible to use the entire body shell as a sound chamber. A simple wall behind the speaker may be all that is possible or perhaps all that is needed.

Speakers can be attached with double sided tape, with glue or with "hot melt". Enclosures can be made with plastic, wood, card stock or even metal. Film cans or medicine bottles make excellent sound chamber enclosures for small diameter speakers. Attachment with "hot melt" is advantageous as the "hot melt" can be used as a gap filler when creating an enclosure.

A second speaker, wired in series with the main speaker, can also enhance sound quality and will

permit a higher volume without damage to the individual speakers. A tube with a speaker at each end or a speaker in a doorway at each end of a body shell is an excellent approach. A four speaker approach will yield the highest volume while still maintaining the 8 ohm minimum requirement. Drawings for this are included in the speaker instructions.

Speaker enclosure is an art and experimentation is definitely in order for your installation so as to gain the maximum benefit of the superb sound quality available in this sound system.

GENERAL OPERATING INFORMATION:

VOLUME ADJUSTMENT: should be set as desired for your application. Please remember that the amplifier can produce more power than a small speaker can handle and that the sound will be louder if the speaker is properly enclosed and baffled. If you are using batteries, the louder the volume the shorter the battery life.

NOTCH ADJUSTMENT: full clockwise for standard 12 volts to the track / motor. Rotate the control CCW for all other operators using higher motor voltages. This control will have no real effect in this system but must be set correctly for higher motor voltages.

<u>SOUND</u>	<u>INDICATION</u>
short.....	apply brakes, stop
2-long.....	release brakes, proceed
long, 3-short.....	flagman protect rear of train
4 or 5 long.....	recall flagman
2-short.....	acknowledgment
3-short.....	back up movement
4-short.....	call for signals
short, long.....	inspect train line for leak or brakes sticking
2-long, short.....	approaching meet or wait point
2-long, short, long.....	approaching grade crossings
continuous long.....	approaching stations or junctions
successive shorts.....	alarm for something on track

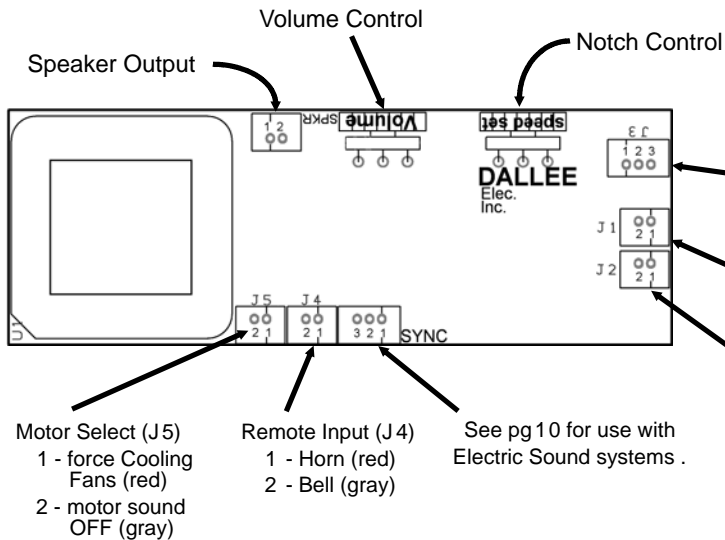

This system features an optically coupled motor input sensor. This means that any connection to J3 pins 1, 2, and 3, do not electrically connect to any other power to the board!

- J3 connections:
- 1 - track RF input (RED)
 - 2 - Motor 1 (BLACK)
 - 3 - Motor 2 (WHITE)

- J1 connections:
- 1 - DCC rail 1also AC input 1.....(RED)
 - 2 - DCC rail 2.....also AC input 2.....(GRAY)

- J2 connections:
- 1 - DC power "+" (RED)
 - 2 - DC power "-" (GRAY)

- Motor Select (J5)
- 1 - force Cooling Fans (red)
 - 2 - motor sound OFF (gray)
- Remote Input (J4)
- 1 - Horn (red)
 - 2 - Bell (gray)
- See pg 10 for use with Electric Sound systems .

SPECIFIC INSTRUCTION SHEETS	
<u>PAGE</u>	<u>INSTALLATION TYPE</u>
3, 4.....	Conventional DC
5.....	Stationary Sound
6.....	DCC receiver
7.....	OTHER receiver
8.....	sample speaker installation

Other wiring / application notes can be found on our web site under "Current Product Instruction Index" then "Sound Related, misc".

NOTE: The speaker impedance should be kept near or above 8 ohms, therefore four 8 ohm speakers in a series/parallel configuration is acceptable since it yields 8 ohms total impedance. If you care to use two 8 ohm speakers you **must** place them in **SERIES**.

DO NOT touch the speaker wires to anything else, this will damage the amplifier which is not covered under warranty!

When connecting DC power to the sound unit be absolutely sure that the "+" and "-" are connect correctly! If not, you will either burn out the sound unit or the supply feeding it. This is not covered under warranty!



246 W. Main St.
Leola, PA 17540
(717) 661-7041
www.dallee.com

DC track power installation using standard batteries & DALLEE controller #755

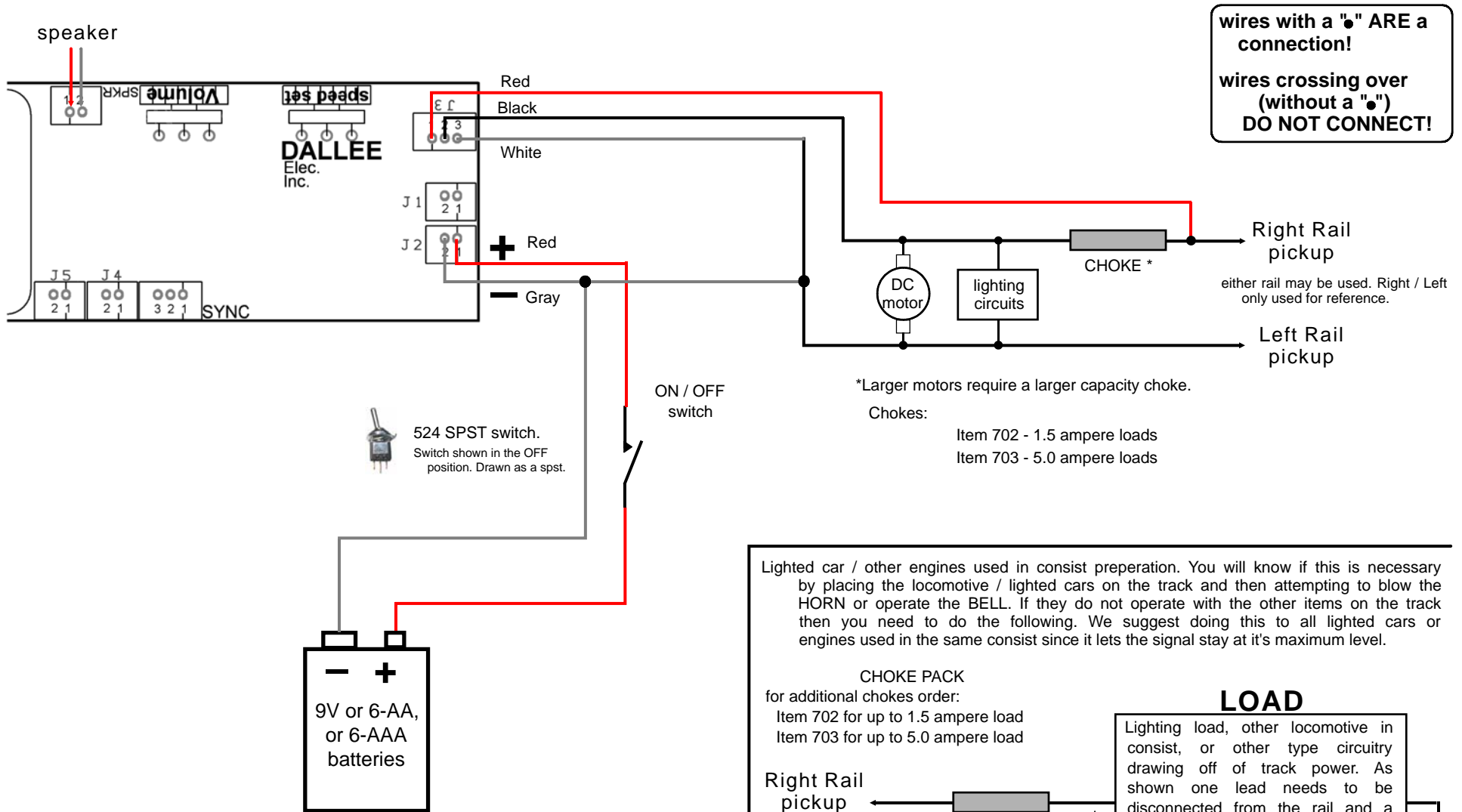

Battery power - must not exceed 24 volts DC. Use one 9 volt battery or a string of 6 AA or AAA batteries (24 volt DC maximum input). Life depends on volume setting and speaker impedance. Typical operation of most sound systems for one good 9 volt batteries is about 8 hours, AA or larger is well beyond 50 hours!

Lighted car / other engines used in consist preparation. You will know if this is necessary by placing the locomotive / lighted cars on the track and then attempting to blow the HORN or operate the BELL. If they do not operate with the other items on the track then you need to do the following. We suggest doing this to all lighted cars or engines used in the same consist since it lets the signal stay at it's maximum level.

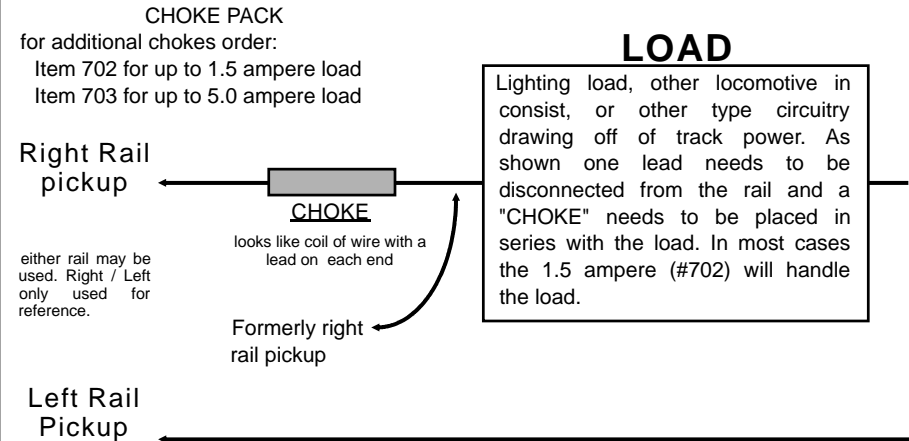

DC track power installation #2 with DALLEE controller #755. With rechargeable or standard battery.

When track voltage exceeds battery voltage, the sound system will operate from track voltage instead of battery voltage.

wires with a "•" ARE a connection!
wires crossing over (without a "•") DO NOT CONNECT!

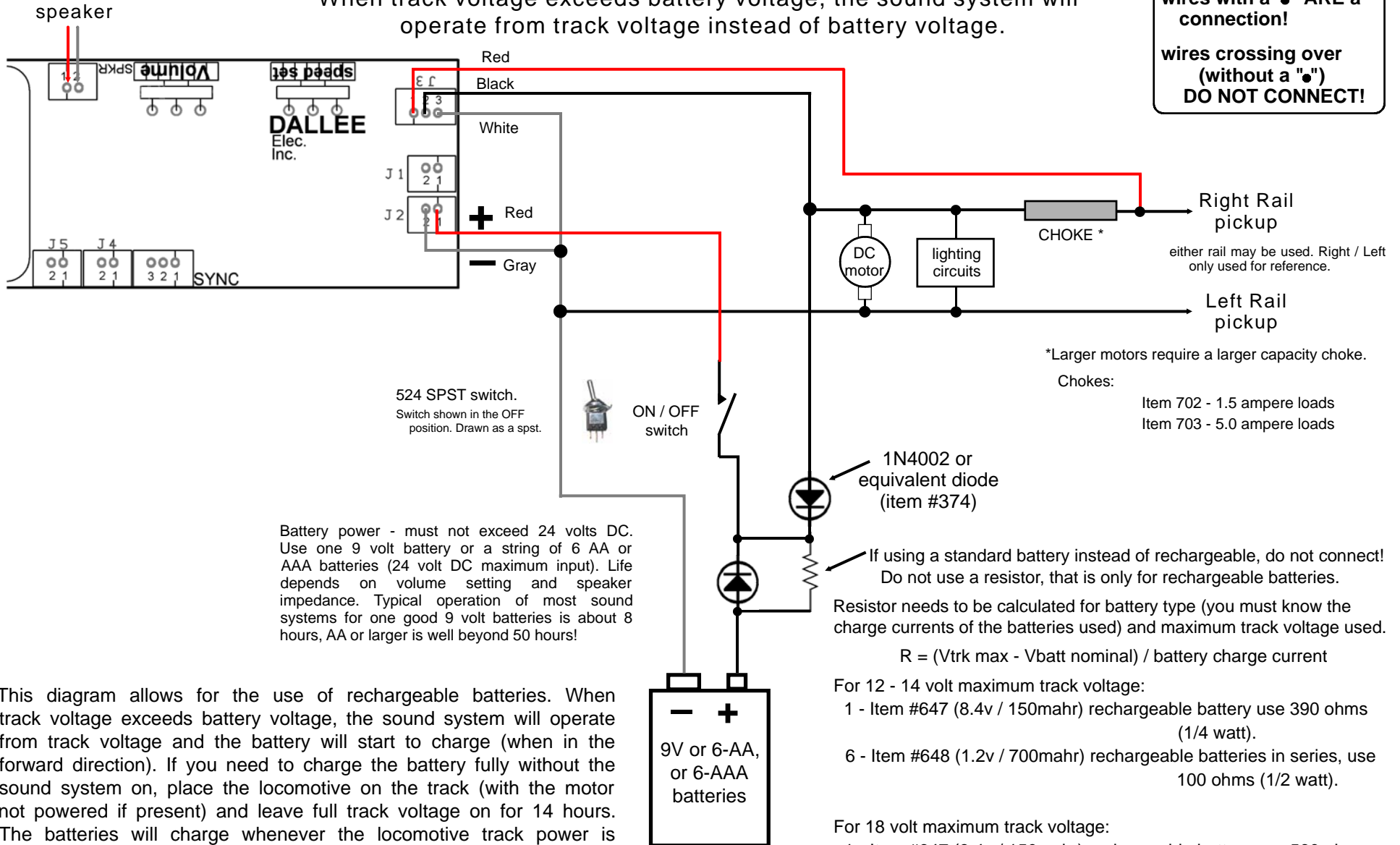

Battery power - must not exceed 24 volts DC. Use one 9 volt battery or a string of 6 AA or AAA batteries (24 volt DC maximum input). Life depends on volume setting and speaker impedance. Typical operation of most sound systems for one good 9 volt batteries is about 8 hours, AA or larger is well beyond 50 hours!

This diagram allows for the use of rechargeable batteries. When track voltage exceeds battery voltage, the sound system will operate from track voltage and the battery will start to charge (when in the forward direction). If you need to charge the battery fully without the sound system on, place the locomotive on the track (with the motor not powered if present) and leave full track voltage on for 14 hours. The batteries will charge whenever the locomotive track power is set for the forward condition regardless of the sound system being on or off. They will not charge when the polarity on the track is set in reverse. When running in reverse, the sound system will only operate from the battery. A bridge rectifier could be used instead of a single diode alleviating this potential problem.

- For 12 - 14 volt maximum track voltage:
- 1 - Item #647 (8.4v / 150mahr) rechargeable battery use 390 ohms (1/4 watt).
 - 6 - Item #648 (1.2v / 700mahr) rechargeable batteries in series, use 100 ohms (1/2 watt).
- For 18 volt maximum track voltage:
- 1 - Item #647 (8.4v / 150mahr) rechargeable battery use 560 ohms (1/4 watt).
 - 6 - Item #648 (1.2v / 700mahr) rechargeable batteries in series, use 180 ohms (1 watt).

Stationary DC power installation using track power for notch setting.

You can also add an auxillary Amplifier, see pages 8, 9, and 10.

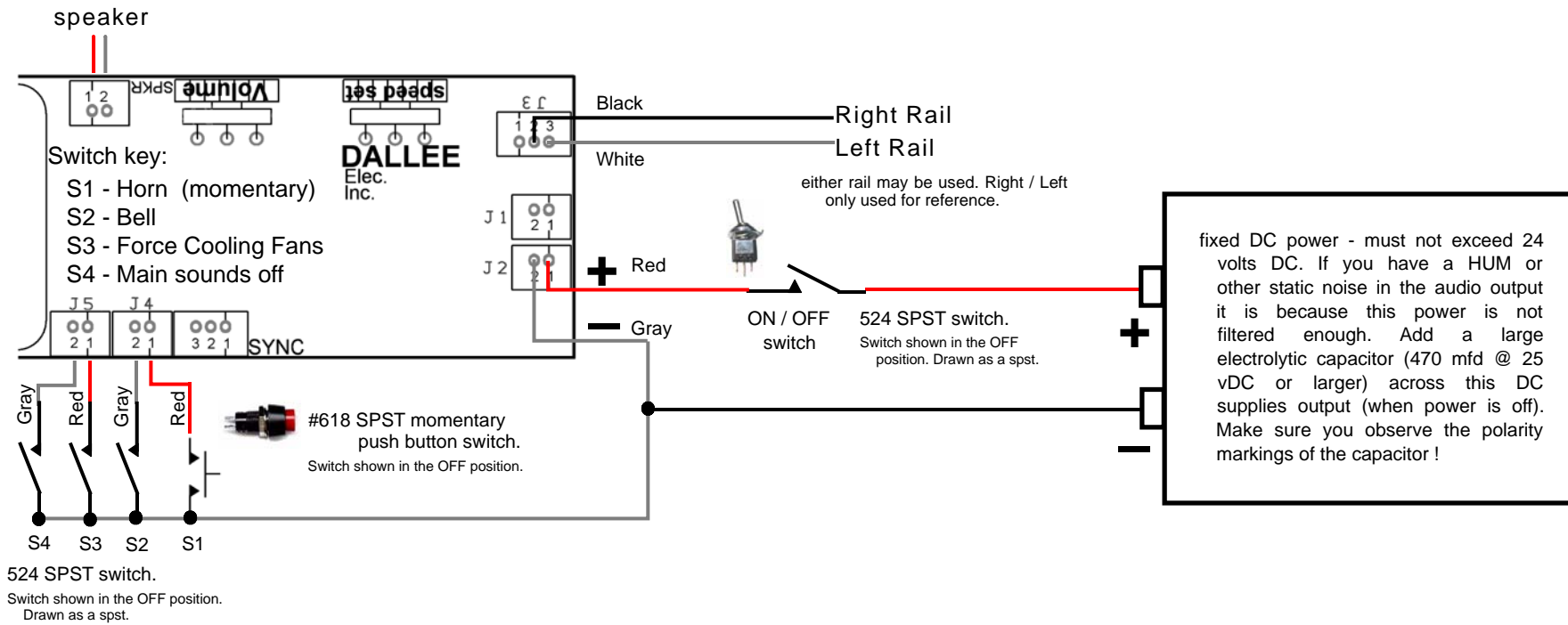

Stationary AC power installation using track power for notch setting.

You can also add an auxillary Amplifier, see pages 8, 9, and 10.

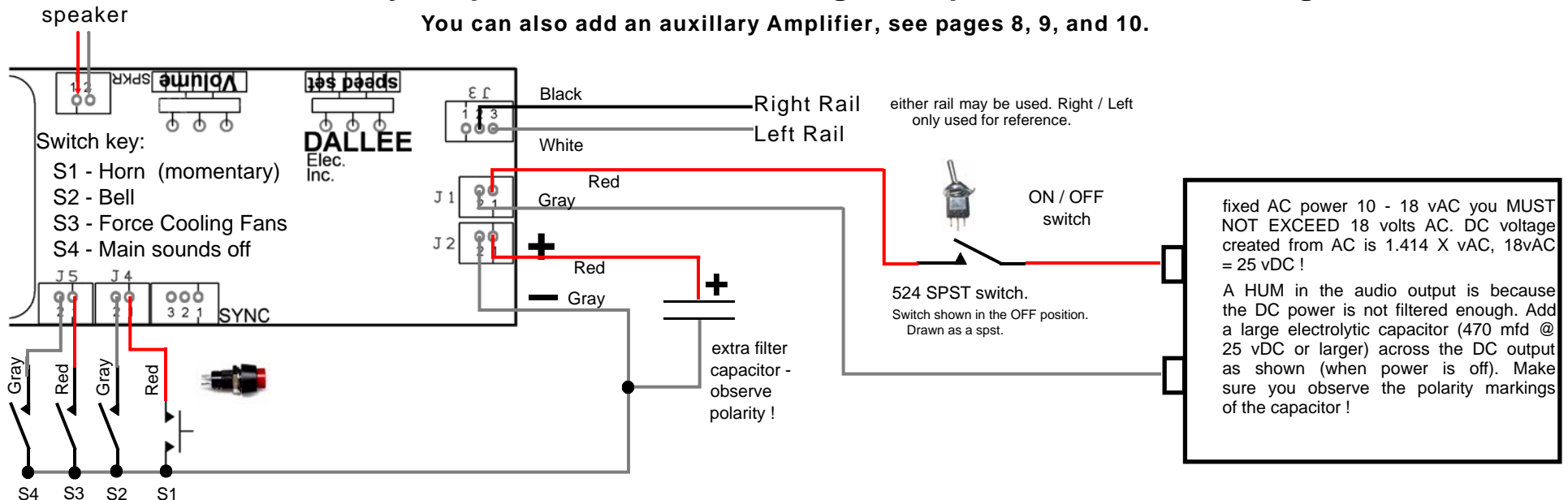

DCC receiver installation using motor power for Main Sound activation and function control for HORN, BELL, Manual Cooling Fans, Main Sounds ON / OFF

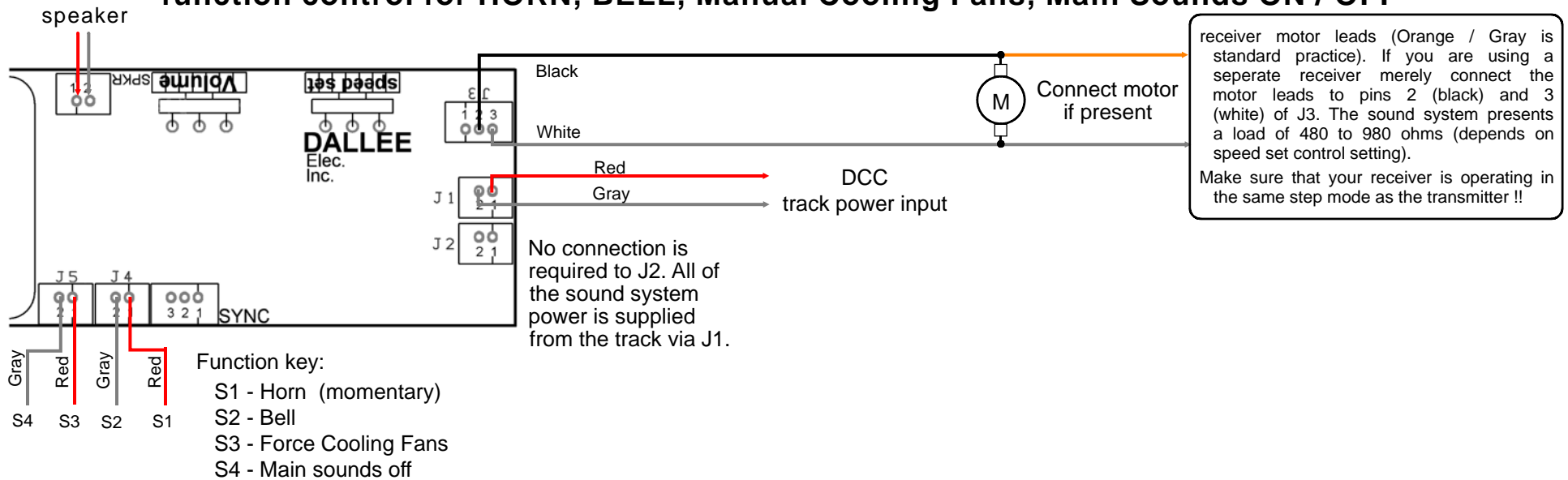

Connect S1 thru S4 to function control desired.
You do not need to connect functions you do not intend on using.

S1 - HORN function. Connect to desired function output of module. Activate low to play HORN.
Some DCC systems offer a momentary type function. It is best to use what the system you are using suggests.
Digitrax - use F2 function
Wangro - use F3 function

S2 - BELL function. Connect to function output of module. Activate low to play BELL.
Suggest function as set by DCC system you are using.
Digitrax - use F1 function
Wangro - use F2 function

S2 -> S4 - function. Connect to extra function, if desired. When using an extra receiver you can use either Forward or Reverse lamp function output of module. Normally not activated = "high". Activated = "low" (function ON).

ATTENTION

ALL FUNCTION CONNECTIONS are for OPEN COLLECTOR type FUNCTIONS such as those found on DIGITRAX, LENZ, NCE, and WANGRO receivers. Although there should not be any problem with any other type, we have not verified it. The sound unit has been designed and operated with WANGRO, DIGITRAX, and LENZ systems to verify DCC operation and compatibility.

ADDITIONAL NOTES:

If you feel that you need longer running time when an intermittent track power input occurs simply attach a larger filter capacitor across the DC power leads (J2). Observe proper polarity. The plus connects to pin 1 (red), minus to pin 2 (gray) - the polarity is very important since some capacitors when connected in reverse can actually blow up like a fire cracker! The larger the capacitor the longer operating time without track power. A capacitor of 470 mfd @ 25vDC should be sufficient, too large of a value will require a very large surge current when track power is applied. Some transmitters cannot take the large surge current on startup and will show an overload condition when powering up.

Other receiver or controller installation using motor power for notch settings and function control for HORN, BELL, Full RPM, Main Sounds ON / OFF

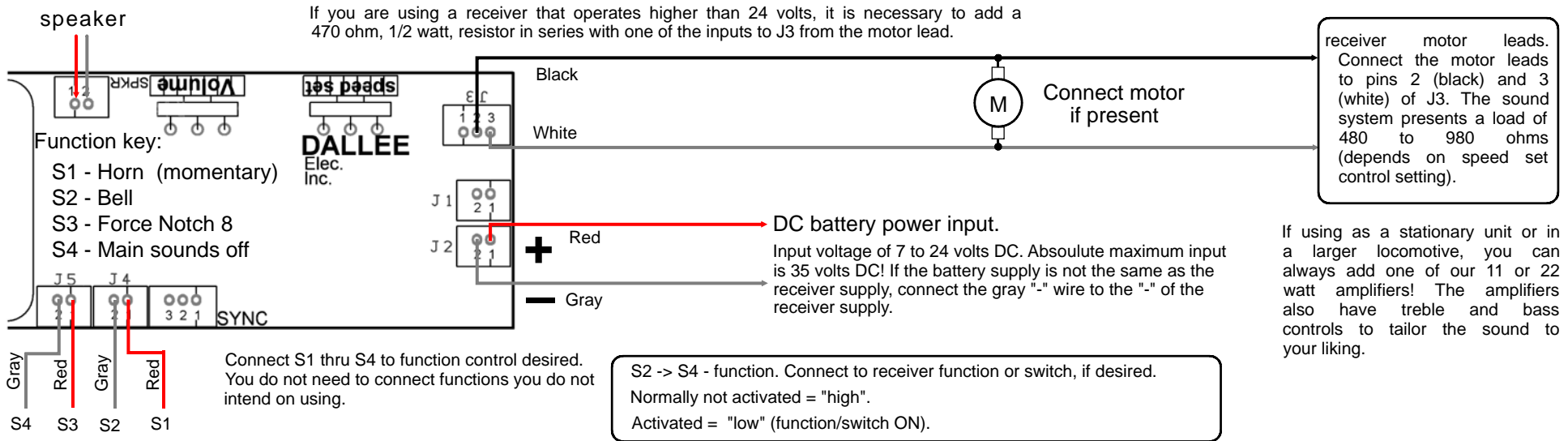

Other receiver or controller installation using motor power for notch settings and switches for HORN, BELL, Full RPM, Main Sounds ON / OFF

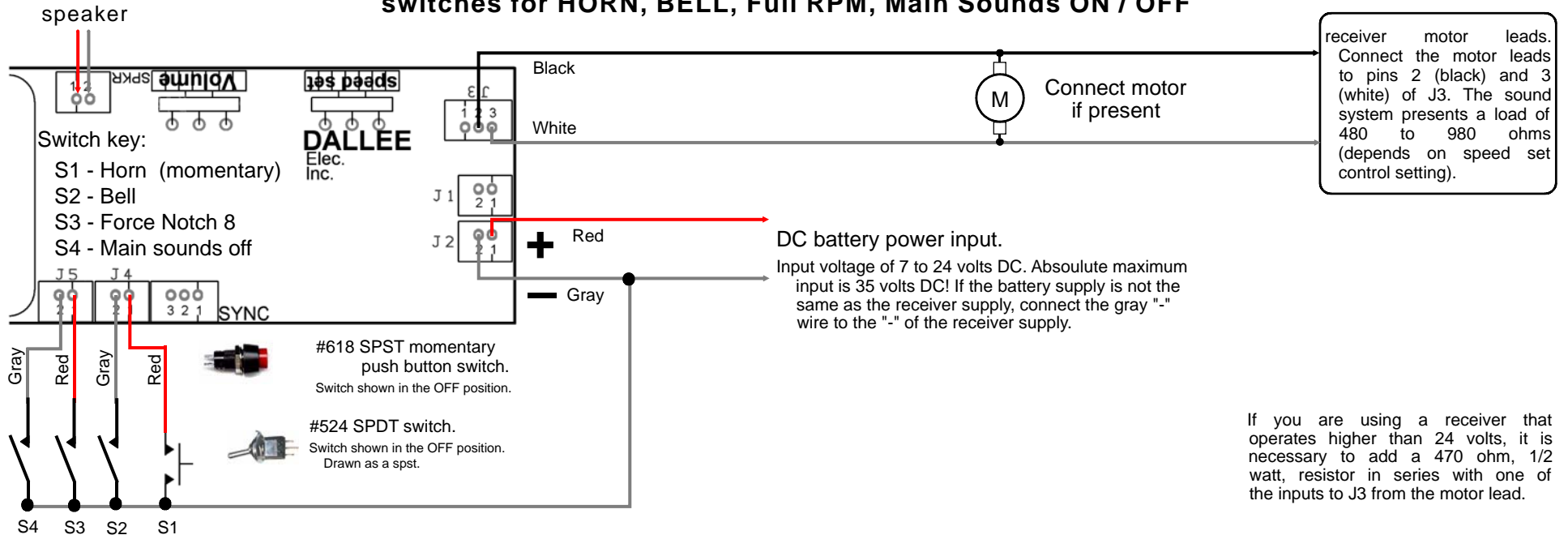

Sample Speaker Installations



For open body shells it is necessary to make a speaker baffle instead of using the body for a baffle. In both cases, the backside of the speaker is closed off.

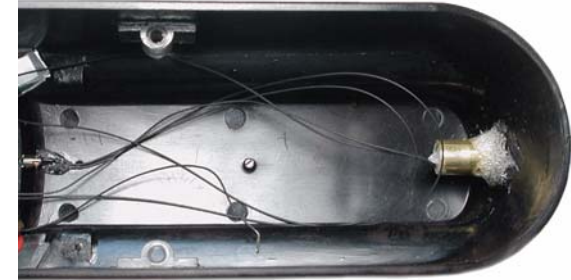

Body shell before speaker installation.



Mounting a speaker facing out from inside of the body. You have to seal all edges of the speaker for a proper baffle.

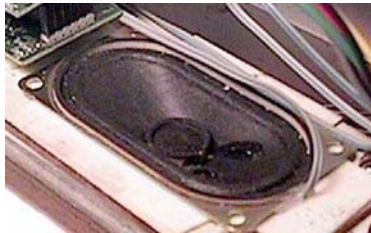

Using the fuel tank as a speaker baffle is quite easy. In this case the speaker emanates sound into the body.



Body shell after speaker installation. Speakers are mounted on a card stock formed shelf and then hot melted in place. Air space is required between the front of the speakers and the body bottom but the back of the speaker enclosure is completely sealed to make a good enclosure / baffle! This type of installation yields more sound per watt than one single speaker.



Mounting speaker in hood of engine using a metal grill for the exhaust.

In the case of a long body, such as the GG1, you can place four speakers inside the shell. As shown above, the body shell is used as the backside of the baffle. The more speakers, the better the sound (especially when using small speakers as in model locomotives. Four speakers make an ideal configuration.